

TOOLING FOR PUNCH PRESSES

# TRUMPF® STYLE

Standard:

**M4 PM**

High Wear Resistance Steel

**HIGH PRECISION TOOLS**

**UNISTAMP™**  
*Always a Step Ahead*



# UNISTAMP™

*Always a Step Ahead*



## ALWAYS INNOVATING TO BRING NEW TECHNOLOGIES TO OUR CUSTOMERS

For more than 35 years UNISTAMP has been the Leader in the Metal Fabricating Sector. Today our company has over 8000 square meters of manufacturing, warehousing and administration. UNISTAMP has representatives throughout the country and abroad. UNISTAMP is made of dedicated professionals who are always in search of technological developments to offer each day better productive solutions. Our technical and commercial team is always at your disposal!

MATERIAL INFORMATION	4
OPTIONS	5
SIZE 0 – TRUMPF® STYLE	6
SIZE I – TRUMPF® STYLE	7
SIZE II – TRUMPF® STYLE	8
SIZE III – TRUMPF® STYLE	9
MULTI TOOL SYSTEM – TRUMPF® STYLE	10
FOR MINIMATIC – TRUMPF® STYLE	11
FOR CS20 – TRUMPF® STYLE	12
DIE ADAPTER – TRUMPF® STYLE	12
STRIPPER'S MODEL	13
SHEAR CONFIGURATION / STANDARD SHAPES	14
KEY DIE POSITION	15
SPECIAL SHAPES	16
SPECIAL TOOLING	18
DIAGONAL DEFINITION	19
CUTTING FORCE	19

## M4 PM – STANDARD STEEL

### High Wear Resistance Steel!

All Trumpf punches are produced with M4 PM.  
The best performance option for the Trumpf  
punch press process!



### Properties Comparison

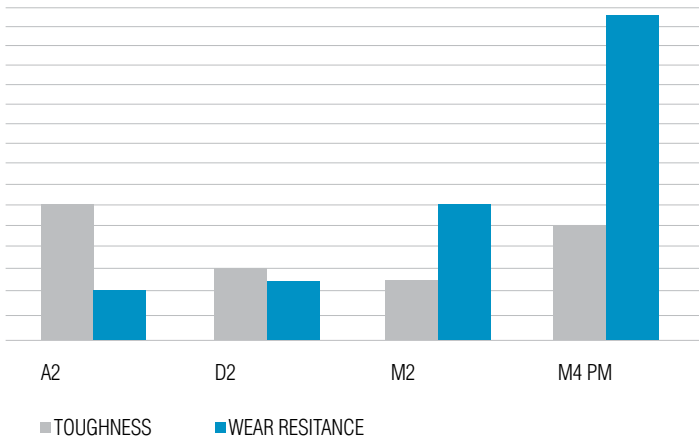

## UNITIN-CR (OPTIONAL)

**A special proprietary coating to extend the life of the punch!**

It is a PVD process (Physical Vapour Deposition). By applying a surface layer on the punch, besides generating high hardness and low friction, the following benefits are obtained:

- More durability cutting edge.
- Prevents adhesive wear
- Protect of abrasive wear
- Decreases friction



## UNISLUG SLUG CONTROL (OPTIONAL)

UNISLUG is an “optional” system that UNISTAMP offers, whose purpose is to avoid return of the slug while punching, eliminating the risk of accumulating slug at the exit of die. So it's a solution for anyone who has this type of problem or that wants to avoid possible problems.

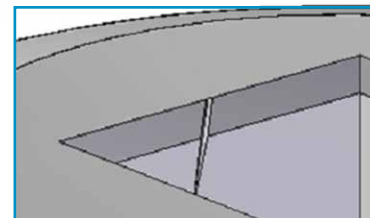
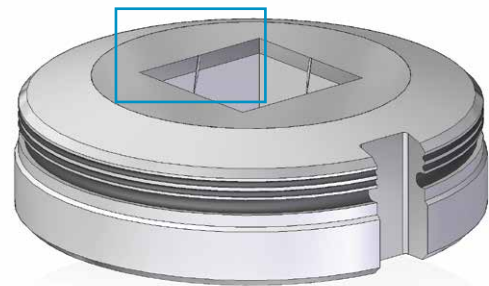

# SIZE 0 – TRUMPF® STYLE

Maximum Diagonal: 0.236" (6.0mm)

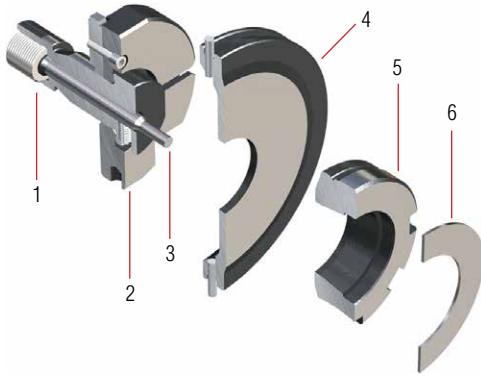

ITEM	CODE	DESCRIPTION
1	9140A17	TR Size 0 (0.236" - 6.0) Punch Chuck
2	9140A14	TR Alignment Ring with Recess
3	9140A01D-M4	TR Size 0 (0.236" - 6.0) M4 Punch Round
3	9140A01F-M4	TR Size 0 (0.236" - 6.0) M4 Punch Shape
3	9140A01DU-M4	TR Size 0 (0.236" - 6.0) M4 with UNITIN-CR Punch Round
3	9140A01FU-M4	TR Size 0 (0.236" - 6.0) M4 with UNITIN-CR Punch Shape
4	9140D03DR	TR Size II Rotation Stripper Round *
4	9140D03FR	TR Size II Rotation Stripper Shape *
4	9140D03D	TR Size II Standard Stripper Round *
4	9140D03F	TR Size II Standard Stripper Shape *
5	9140C02D	TR Size I Die Round
5	TR Size I Die Round	TR Size I (Keyed 0°/45°/90°) Die Shape
6	9140C40-0.5	TR Size I Shim to Die - Thickness .020" (0.5mm)
6	9140C40-1.0	TR Size I Shim to Die - Thickness .039" (1.0mm)

Maximum Diagonal: 0.413" (10.5mm)

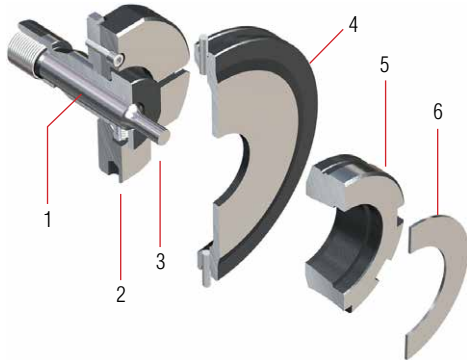

ITEM	CODE	DESCRIPTION
1	9140A17	TR Size 0 (0.236" - 6.0) Punch Chuck
2	9140A14	TR Alignment Ring with Recess
3	9140A01D-M4	TR Size 0 (0.236" - 6.0) M4 Punch Round
3	9140A01F-M4	TR Size 0 (0.236" - 6.0) M4 Punch Shape
3	9140B01DU-M4	TR Size 0 (0.413" - 10.5) M4 with UNITIN-CR Punch Round
3	9140B01FU-M4	TR Size 0 (0.413" - 10.5) M4 with UNITIN-CR Punch Shape
4	9140D03DR	TR Size II Rotation Stripper Round *
4	9140D03FR	TR Size II Rotation Stripper Shape *
4	9140D03D	TR Size II Standard Stripper Round *
4	9140D03F	TR Size II Standard Stripper Shape *
5	9140C02D	TR Size I Die Round
5	9140C02F3	TR Size I (Keyed 0°/45°/90°) Die Shape
6	9140C40-0.5	TR Size I Shim to Die - Thickness .020" (0.5mm)
6	9140C40-1.0	TR Size I Shim to Die - Thickness .039" (1.0mm)

## PUNCH & DIE GRINDING

Grind Length: 0.079" (2.0mm)

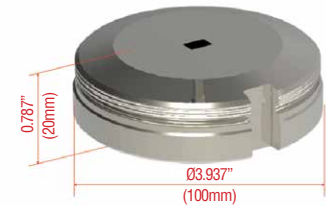

Grind Length: 0.079" (2.0mm)

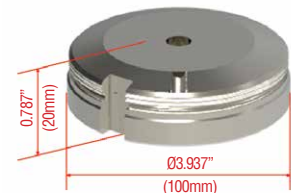

## NOTE

Strong Profile  
Standard for Round or Shape with  
dimensions ≤ 0.018" (3.0mm)  
Grind Length: 0.079" (2.0mm)

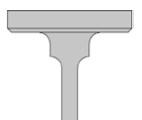

\* For choose stripper's model, consult page "13"

# SIZE I – TRUMPF® STYLE

Maximum Diagonal: 1.220" (31.0mm)

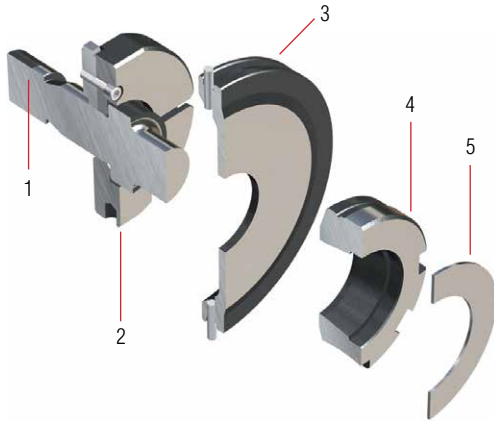

ITEM	CODE	DESCRIPTION
1	9140C01D-M4	TR Size I (1.220" - 31.0) M4 Punch Round
1	9140C01F-M4	TR Size I (1.220" - 31.0) M4 Punch Shape
1	9140C01DU-M4	TR Size I (1.220" - 31.0) M4 UNITIN-CR Punch Round
1	9140C01FU-M4	TR Size I (1.220" - 31.0) M4 UNITIN-CR Punch Shape
2	9140A14	TR Alignment Ring with Recess
3	9140D03DR	TR Size II Rotation Stripper Round *
3	9140D03DR	TR Size II Rotation Stripper Shape *
3	9140D03D	TR Size II Standard Stripper Round *
3	9140D03F	TR Size II Standard Stripper Shape *
4	9140C02D	TR Size I Die Round
4	9140C02F3	TR Size I (Keyed 0°/45°/90°) Die Shape
5	9140C40-0,5	TR Size I Shim to Die - Thickness .020" (0.5mm)
5	9140C40-1,0	TR Size I Shim to Die - Thickness .039" (1.0mm)

\* For choose stripper's model, consult page "13"

## PUNCH & DIE GRINDING

Grind Length: 0.079" (2.0mm)

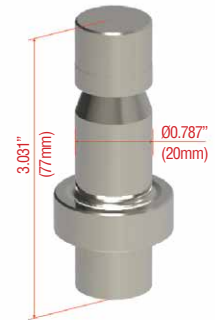

Grind Length: 0.079" (2.0mm)

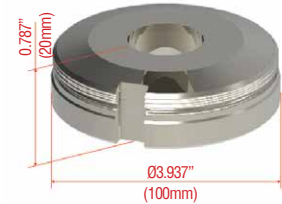

## NOTE

Strong Profile  
Standard for Round or Shape with  
dimensions ≤ 0.018" (3.0mm)  
Grind Length: 0.079" (2.0mm)

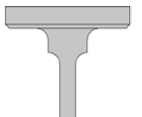

# SIZE II – TRUMPF® STYLE

Maximum Diagonal: 3.008" (76.4mm)

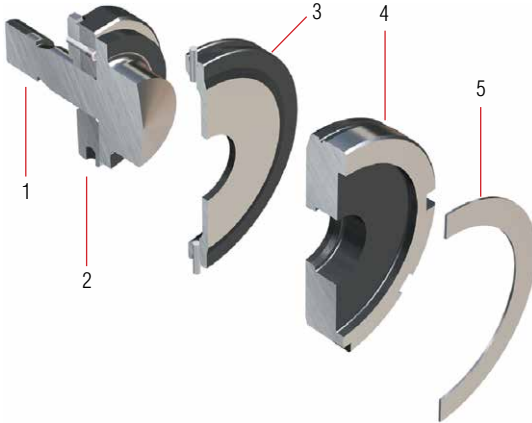

ITEM	CODE	DESCRIPTION
1	9140DA01D-M4	TR Size II (1.378" - 35.0) M4 Punch Round
1	9140DA01F-M4	TR Size II (1.378" - 35.0) M4 Punch Shape
1	9140DA01DU-M4	TR Size II (1.378" - 35.0) M4 UNITIN-CR Punch Round
1	9140DA01FU-M4	TR Size II (1.378" - 35.0) M4 UNITIN-CR Punch Shape
1	9140DB01D-M4	TR Size II (1.496" - 38.0) M4 Punch Round
1	9140DB01F-M4	TR Size II (1.496" - 38.0) M4 Punch Shape
1	9140DB01DU-M4	TR Size II (1.496" - 38.0) M4 UNITIN-CR Punch Round
1	9140DB01FU-M4	TR Size II (1.496" - 38.0) M4 UNITIN-CR Punch Shape
1	9140DC01D-M4	TR Size II (1.772" - 45.0) M4 Punch Round
1	9140DC01F-M4	TR Size II (1.772" - 45.0) M4 Punch Shape
1	9140DC01DU-M4	TR Size II (1.772" - 45.0) M4 UNITIN-CR Punch Round
1	9140DC01FU-M4	TR Size II (1.772" - 45.0) M4 UNITIN-CR Punch Shape
1	9140D01D-M4	TR Size II (1.890" - 48.0) M4 Punch Round
1	9140D01F-M4	TR Size II (1.890" - 48.0) M4 Punch Shape
1	9140D01DU-M4	TR Size II (1.890" - 48.0) M4 UNITIN-CR Punch Round
1	9140D01FU-M4	TR Size II (1.890" - 48.0) M4 UNITIN-CR Punch Shape
1	9140EA01D-M4	TR Size II (2.146" - 54.5) M4 Punch Round
1	9140EA01F-M4	TR Size II (2.146" - 54.5) M4 Punch Shape
1	9140EA01DU-M4	TR Size II (2.146" - 54.5) M4 UNITIN-CR Punch Round
1	9140EA01FU-M4	TR Size II (2.146" - 54.5) M4 UNITIN-CR Punch Shape
1	9140E01D-M4	TR Size II (2.382" - 60.5) M4 Punch Round
1	9140E01F-M4	TR Size II (2.382" - 60.5) M4 Punch Shape
1	9140E01DU-M4	TR Size II (2.382" - 60.5) M4 UNITIN-CR Punch Round
1	9140E01FU-M4	TR Size II (2.382" - 60.5) M4 UNITIN-CR Punch Shape
1	9140F01D-M4	TR Size II (3.008" - 76.4) M4 Punch Round
1	9140F01F-M4	TR Size II (3.008" - 76.4) M4 Punch Shape
1	9140F01DU-M4	TR Size II (3.008" - 76.4) M4 UNITIN-CR Punch Round
1	9140F01FU-M4	TR Size II (3.008" - 76.4) M4 UNITIN-CR Punch Shape
3	9140D03DR	TR Size II Rotation Stripper Round *
3	9140D03FR	TR Size II Rotation Stripper Shape *
3	9140D03D	TR Size II Standard Stripper Round *
3	9140D03F	TR Size II Standard Stripper Shape *
4	9140D02D	TR Size II Die Round
4	9140D02F3	TR Size II (Keyed 0°/45°/90°) Die Shape
5	9140D40-0,5	TR Size II Shim to Die - Thickness .020" (0.5mm)
5	9140D40-1,0	TR Size II Shim to Die - Thickness .039" (1.0mm)

## PUNCH & DIE GRINDING

Grind Length: 0.079" (2.0mm)

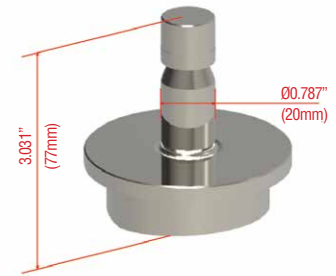

Grind Length: 0.079" (2.0mm)

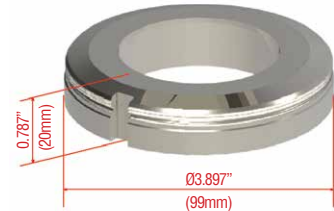

## NOTE

Strong Profile  
Standard for Round or Shape with  
dimensions ≤ 0.018" (3.0mm)  
Grind Length: 0.079" (2.0mm)

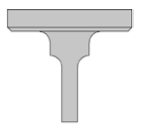

## STANDARD

Rooftop

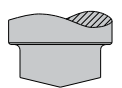

\* For choose stripper's model, consult page "13"



# SIZE III – TRUMPF® STYLE

Maximum Diagonal: 4.016" (102.0mm)

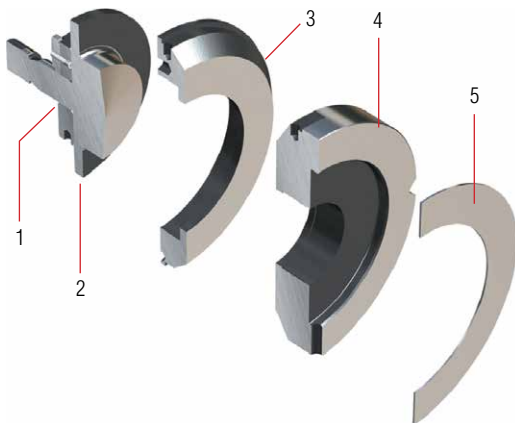

ITEM	CODE	DESCRIPTION
1	9140D14	TR Alignment Ring without Recess
2	9140G01D-M4	TR Size III (3.543" - 90.0) M4 Punch Round
2	9140G01F-M4	TR Size III (3.543" - 90.0) M4 Punch Shape
2	9140G01DU-M4	TR Size III (3.543" - 90.0) M4 UNITIN-CR Punch Round
2	9140G01FU-M4	TR Size III (3.543" - 90.0) M4 UNITIN-CR Punch Shape
2	9140H01F-M4	TR Size III (4.016" - 102.0) M4 Punch Round
2	9140H01D-M4	TR Size III (4.016" - 102.0) M4 Punch Shape
2	9140H01FU-M4	TR Size III (4.016" - 102.0) M4 UNITIN-CR Punch Round
2	9140H01DU-M4	TR Size III (4.016" - 102.0) M4 UNITIN-CR Punch Shape
3	9140G03D	TR Size III Stripper Round
3	9140G03F	TR Size III Stripper Shape
4	9140G02D	TR Size III Die Round
4	9140G02F	TR Size III Die Shape
5	9140G40-0.5	TR Size III Shim to Die - Thickness .020" (0.5mm)
5	9140G40-1.0	TR Size III Shim to Die - Thickness .039" (1.0mm)

## PUNCH & DIE GRINDING

Grind Length: 0.079" (2.0mm)



Grind Length: 0.079" (2.0mm)

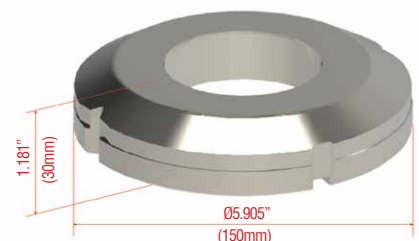

## NOTE

Strong Profile  
Standard for Round or Shape with  
dimensions  $\leq 0.018"$  (3.0mm)  
Grind Length: 0.079" (2.0mm)

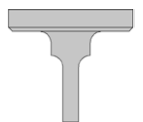

## STANDARD

Rooftop



# MULTI TOOL SYSTEM – TRUMPF® STYLE

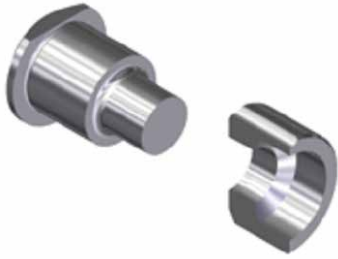

## 5 STATION - MT5

**Maximum Diagonal:**  
**0.630" (16.0mm)**

ITEM	CODE	DESCRIPTION
1	9140I01D	TR MT-5 Punch Round
1	9140I01F	TR MT-5 Punch Shape
1	9140I01DU	TR MT-5 UNITIN-CR Punch Round
1	9140I01FU	TR MT-5 UNITIN-CR Punch Shape
2	9140I02D	TR MT-5 Die Round
2	9140I02F	TR MT-5 Die Shape

### PUNCH & DIE GRINDING

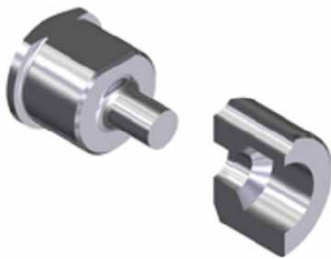

## 6 STATION - MT6

**Maximum Diagonal:**  
**0.630" (16.0mm)**

ITEM	CODE	DESCRIPTION
1	9140J01D-M4	TR MT-6 M4 Punch Round
1	9140J01F-M4	TR MT-6 M4 Punch Shape
1	9140J01DU-M4	TR MT-6 M4 UNITIN-CR Punch Round
1	9140J01FU-M4	TR MT-6 M4 UNITIN-CR Punch Shape
2	9140J02D	TR MT-6 Die Round
2	9140J02F	TR MT-6 Die Shape

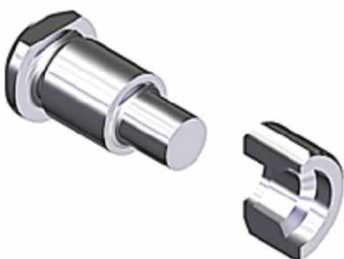

## 10 STATION - MT10

**Maximum Diagonal:**  
**0.413" (10.5mm)**

ITEM	CODE	DESCRIPTION
1	9140K01D-M4	TR MT-10 M4 Punch Round
1	9140K01F-M4	TR MT-10 M4 Punch Shape
1	9140K01DU-M4	TR MT-10 M4 UNITIN-CR Punch Round
1	9140K01FU-M4	TR MT-10 M4 UNITIN-CR Punch Shape
2	9140K02D	TR MT-10 Die Round
2	9140K02F	TR MT-10 Die Shape



### NOTE

Strong Profile  
Standard for Round or Shape with  
dimensions ≤ 0.018" (3.0mm)  
Grind Length: 0.079" (2.0mm)

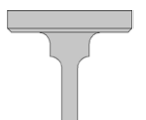

# FOR MINIMATIC – TRUMPF® STYLE



ITEM	CODE	DESCRIPTION
	9140C03D	TR Size I (Minimatic) Stripper Round
	9140C03F	TR Size I (Minimatic) Stripper Shape

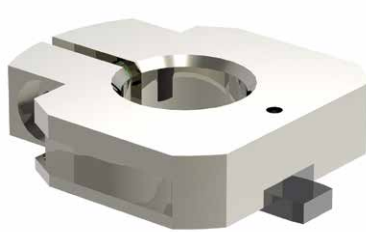
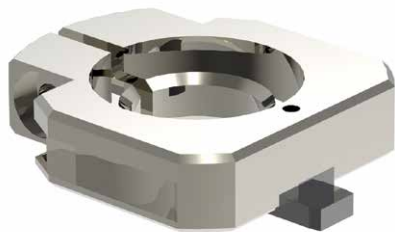

ITEM	CODE	DESCRIPTION
	50045	TR Alignment Ring (Minimatic) with Recess
	50046	TR Alignment Ring (Minimatic) without Recess

# FOR CS20 – TRUMPF® STYLE

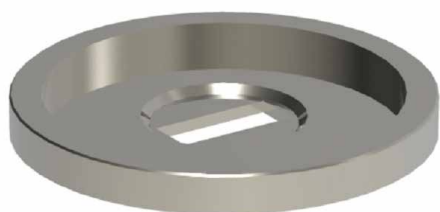

ITEM	CODE	DESCRIPTION
	9140D03DC	TR Size II (CS20) Stripper Round
	9140D03FC	TR Size II (CS20) Stripper Shape

# DIE ADAPTER – TRUMPF® STYLE



ITEM	CODE	DESCRIPTION
	9140B44	Die Adapter TR (Size II to Size I)
	9140C44	Die Adapter TR (Size III to Size II)

# STRIPPER'S MODEL

---

## TR SIZE II ROTATION STRIPPER

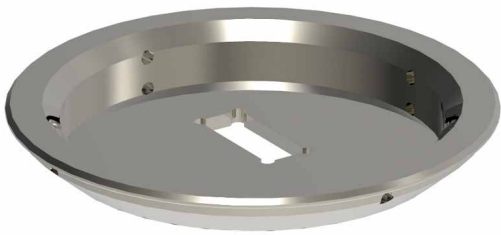

## TR SIZE II STANDARD STRIPPER

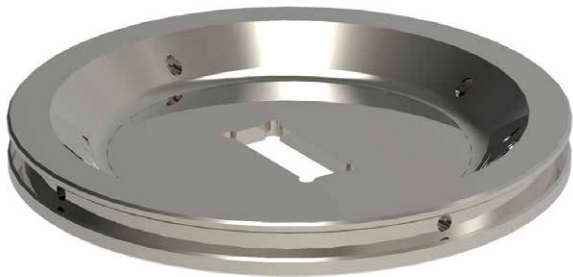

## TR SIZE I MINIMATIC STRIPPER



# SHEAR CONFIGURATION / STANDARD SHAPES

## SHEAR OPTIONS

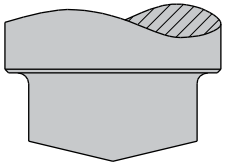

### Rooftop

Standard for Stations D, E, F, G, H, J. A good option for reduce the cutting force and noise.

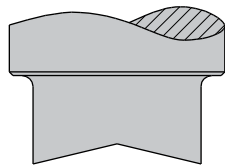

### Inverted Rooftop

Better shear for Nibbling

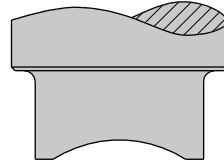

### Concave

Best Shear for Nibbling

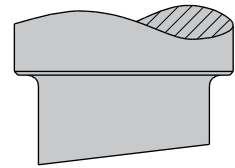

### Whisper/Scissors

Reduce cutting force

## LIMITATION

Not good for nibbling. It is necessary to have 75% of point length engaged to avoid excessive side load.

Most likely breakage will occur because of stresses at sharp points.

Not good for high tonnages, because of inverted stresses

Most likely breakage because of stress sharp. This Shear model direct the stress one-sided

## STANDARD SHAPES

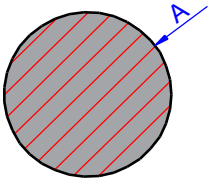

Round

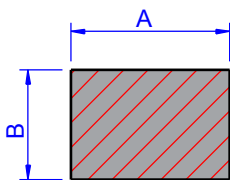

Rectangle

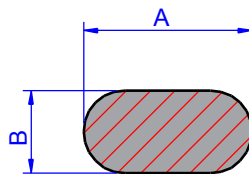

Obround

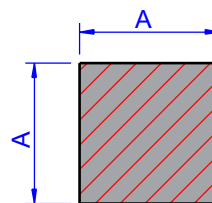

Square

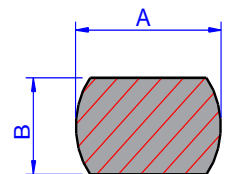

Double-D

# KEY DIE POSITION

Die Station	Type	Standard	Square Shape
I	Key	0°, 45° and 90°	0°, 45° and 90°
II	Key	0°, 45° and 90°	0°, 45° and 90°
III	Key	0°	0°

When ordering shapes at non-standard, Use the diagrams below

## Unistamp Tool's keying diagram

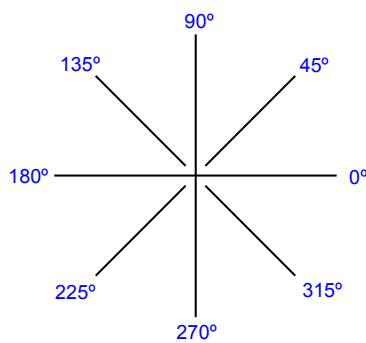

Die View

### Example

Shape at 30°

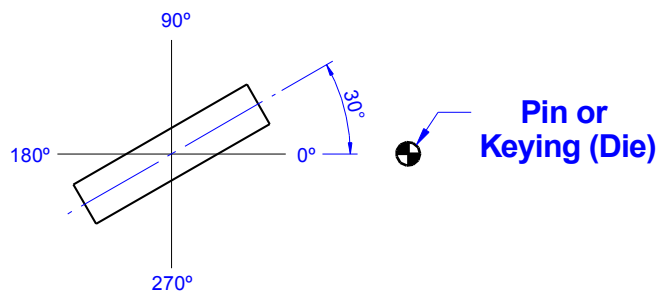

# SPECIAL SHAPES

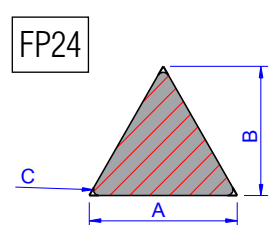
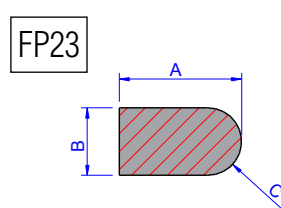
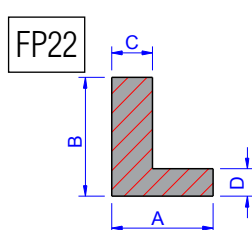
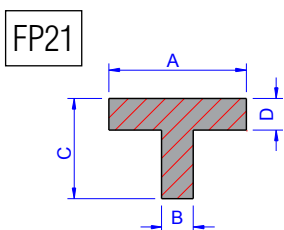
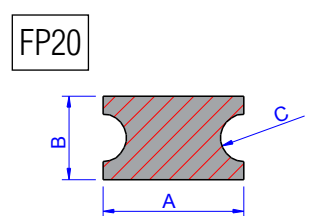
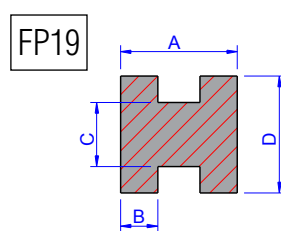
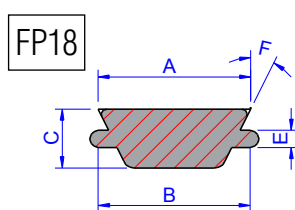
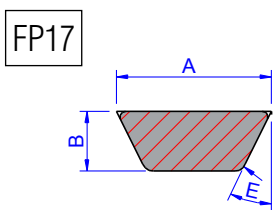
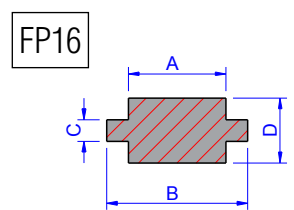
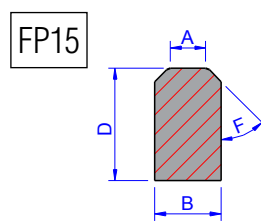
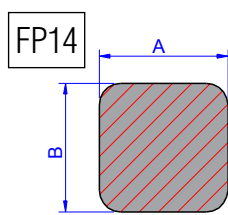
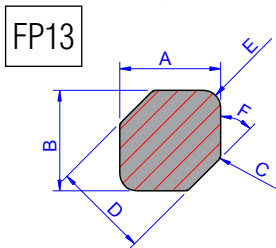
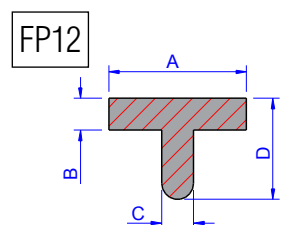
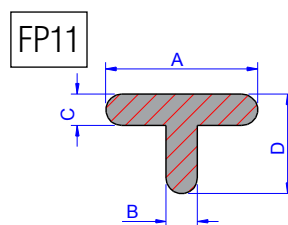
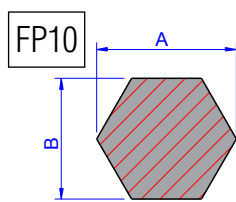
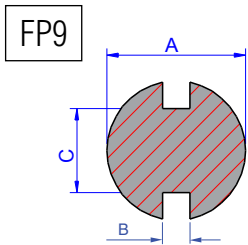
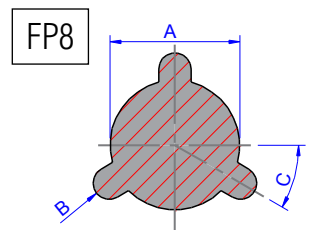
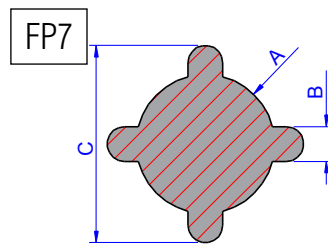
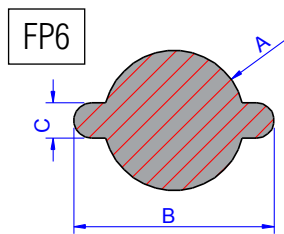
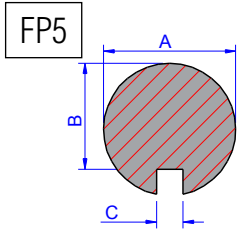
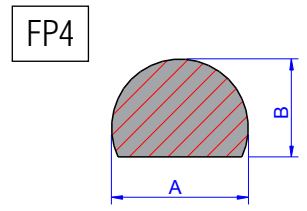
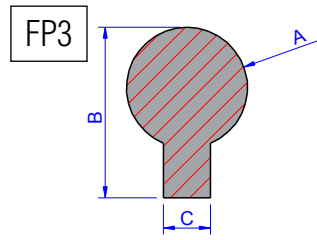
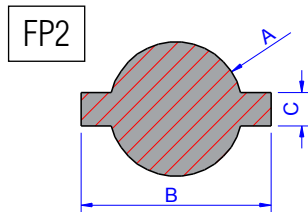
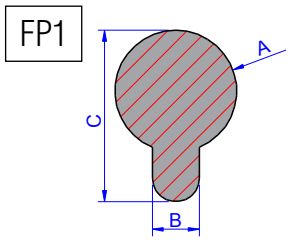



# SPECIAL SHAPES

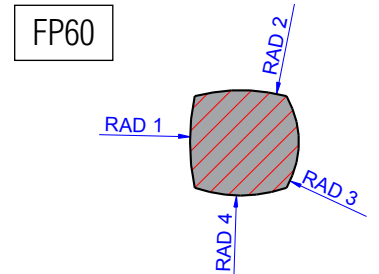
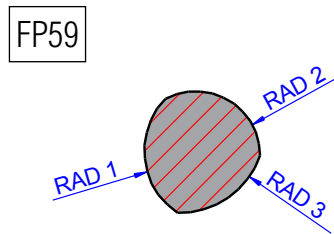
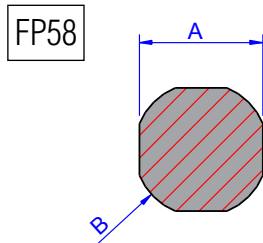
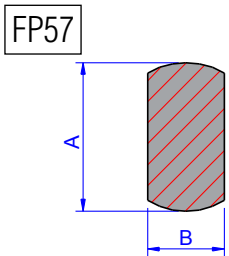
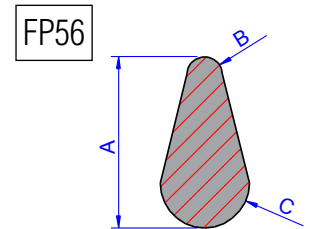
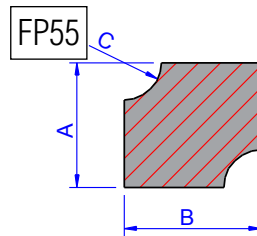
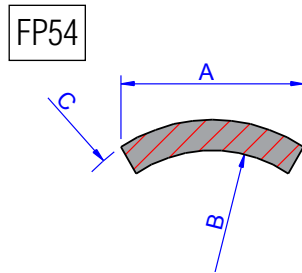
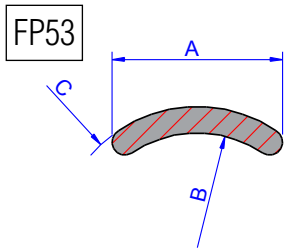
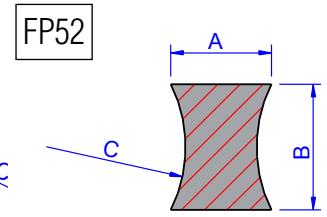
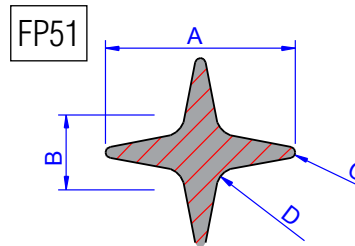
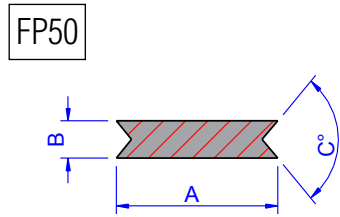
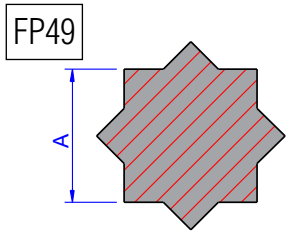
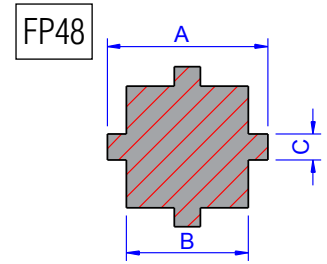
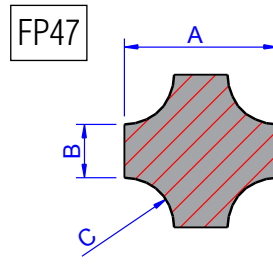
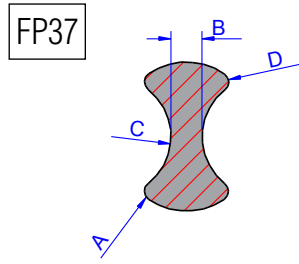
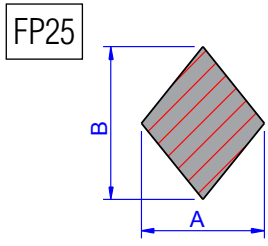

**Multiple profiles**  
**Multiple shapes**



**Extrusion (Form-Up)**

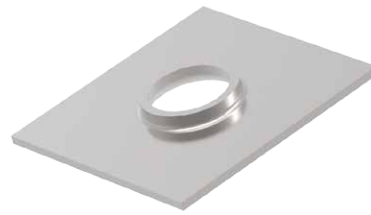
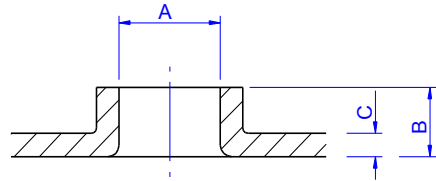

**Louvers (Form-Up)**

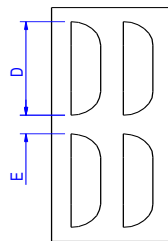
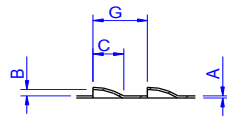

**Mark**

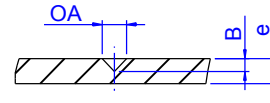

**Countersink**

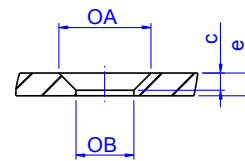

**Cluster Tool**

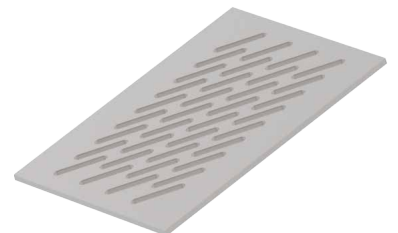
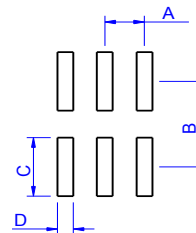
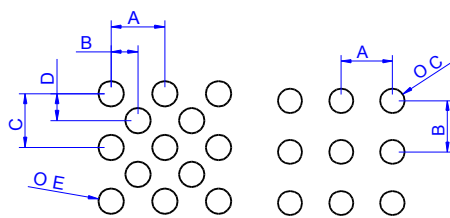
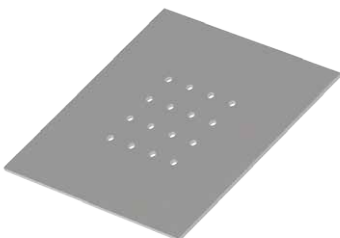

# DIAGONAL DEFINITION

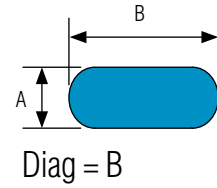
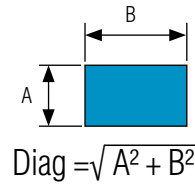
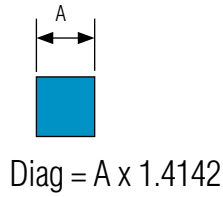
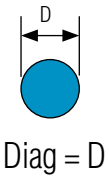

## How to choose correct station considering diagonal size?

### Situation 1

#### ROUND HOLE Ø3/8" (0.375")

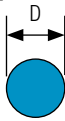
For round, should to use:  Diag = D  
Diagonal = 0.375"

**Station A (≤ 0.413")**

Important: "Punch Chuck" is necessary to use for Size 0.  
If not available, you should use size 1.

### Situation 2

#### SQUARE SHAPE 2"

For round, should to use:  Diag = A x 1.4142  
Diag = 2" x 1.4142 = 2.828"  
Diagonal = 2.828"

**Size II 3.008"**

Important: It's not possible utilize size II 2.382" or smaller,  
because the Diagonal (2.828") is bigger than flange.

Small Flange



Big Flange



# CUTTING FORCE



$$Cf = P \cdot t \cdot \tau$$

Cf = Cutting force  
P = Shape perimeter  
t = Plate thickness  
 $\tau$  = Shear Stress

### Shear Stress

Aluminium	≈21,320 psi (*)	≈147 MPa (*)
Mild steel	≈56,564 psi (*)	≈390 MPa (*)
Stainless steel	≈84,121 psi (*)	≈580 MPa (*)

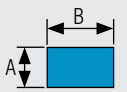
### Shape perimeter

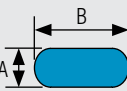
	P = D . 3.1416		P = 2 x (A+B)
	P = D . 3.1416		P = 2x(B-A) + (Ax3.1416)

### Situation 1

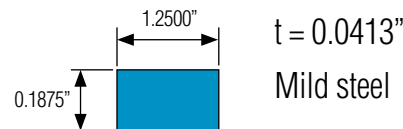

$$P = 2 \times (A + B)$$

$$P = 2 \times (0.1875 + 1.2500)$$

$$P = 2.875"$$

$$Cf = 2.875 \times 0.0413 \times 56,564$$

$$Cf = 6,716 \text{ lbs}$$

**UNISTAMP**<sup>TM</sup>  
*Always a Step Ahead*

Rod. Edgard Máximo Zamboto | Km 68 | Caixa Postal 293  
Jarinú SP | 13240-970 | Brasil | Tel/PABX: 55 11 4016 0250  
unistamp@unistamp.com.br | [www.unistamp.com](http://www.unistamp.com)